

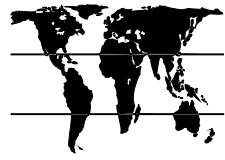

**DTU**   **KENDAT**

# **Animal Cart Programme**

---

TECHNICAL  
**46**  
RELEASE

## **Straight Hame Collar for Donkey Harness**

Development Technology Unit, Department of Engineering, University of Warwick, Coventry, CV4 7AL UK, tel: +44 (0)1203 523523 extn 2339, fax: +44 (0)1203 418922, email: [dtu@eng.eng.warwick.ac.uk](mailto:dtu@eng.eng.warwick.ac.uk)  
KENDAT, PO Box 61441, Nairobi, Kenya, tel/fax: +254 2 766939, email: [kendat@africaonline.co.ke](mailto:kendat@africaonline.co.ke)

Figure 1: straight hame collar for donkeys - wooden version.



# Straight Hame Collar Harness for Donkeys made from Steel Tubing, or Timber

## Introduction

This technical release covers the manufacture of a straight hame collar for donkeys. Collars allow the highest draught (pull) from a particular animal. Collars can be used to pull carts or agricultural implements. This chapter shows both a steel and a wooden design.

You should find that you can make the wooden collar for one donkey for less than £<sub>UK</sub>1 and the steel one for about £<sub>UK</sub>3, depending on the cost of the materials and labour. Once you get organised, a man can probably make a collar in a few hours.

## Idea Behind Design

Collars are used in many countries to harness animals for draught (pull). Most of the designs we have seen have curved hames (the wood or metal parts pressing on the sides of the animal's necks), but some countries have used straight pieces of wood here and our experience suggests that this will work adequately if not well - depending on the shape of the donkey. Most of the donkeys we have seen in Kenya, Uganda and South Africa would be fine with straight hames.

Special tools and jigs and hard-to-get materials are not required for these designs - the only tools which you must have are a woodsaw and hammer - and for the steel design, a simple welder and hacksaw.

## Cutting lists and costs

Tables 1 and 2 show the cutting lists for complete collars -



**Figure 2: steel version of straight hame donkey collar.**

recent prices of materials in Kenya are shown converted into £<sub>UK</sub> to assist international comparison.

### Construction step by step (steel version)

- 1) Get all the material together and clear a space to work.  
Ideally you will be able to work on a flat area of concrete or have access to a bench and vice.
- 2) Cut two pieces of 50 mm diameter steel pipe 450 mm long.
- 3) Using a hacksaw, angle grinder or welder set to maximum current, cut the slots for the hame cross bar as shown in Figure 3.
- 4) Make a top ring for each hame by winding some 8 mm round bar around a piece of the tube and weld it to the top of each hame to close off the end of the slots.

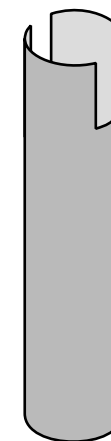

Figure 3: slot cut in top of steel hame.

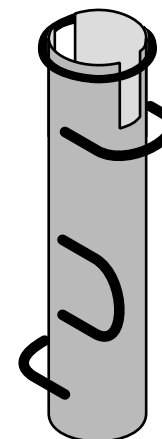
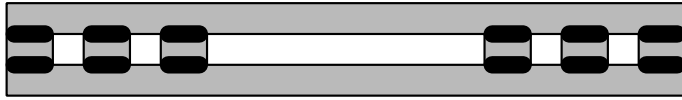

Figure 4: attachment loops and top ring welded to steel hame.

TABLE 1: steel straight hame collar materials cutting list.

component	material	# components	total mat [mm]	mat cost [£ <sub>UK</sub> ]
main frames	50 round tubing	2*450	900.00	0.97
padding clips	8 mm re bar	2*2*40	160.00	0.02
U loops	8 mm re bar	2*3*125	750.00	0.07
top link	8 mm re bar	2*250	500.00	0.05
strap hooks	8 mm re bar	2*150	300.00	0.03
top link pins	scrap tyre rubber	1*8*70	10.00	0.10
			<b>TOTAL =</b>	<b>1.25</b>



**Figure 5: welding of hame cross bar.**

- 5) Make up the hame cross bar shown in Figure 5.
- 6) Cut some scrap tyre rubber to make pegs to stop the hame cross bar pulling through the hames.
- 7) Cut 125 mm lengths of 8 mm diameter round steel bar and bend them into U shaped loops.

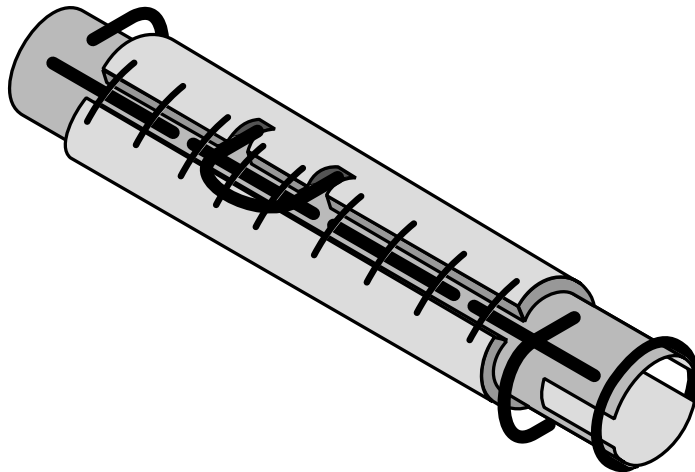

**Figure 6: padding tied to hame with wire or cord.**

- 8) Weld the U loops onto the tubes in the places indicated in the drawings.
- 9) Either:
  - wind the padding rope around the tube and fix the ends,
  - or fix padding cloth, blanket or carpet to the hames using wire or cord as shown in Figure 6.
- 10) Make up some attachment hooks as shown in Figure 8.

### **Construction step by step (wood version)**

- 1) As always get the material together and clear a space to work. Ideally you will have a flat area of concrete or have access to a bench and vice.
- 2) Cut two 450 mm long pieces of timber about 50 mm in

**TABLE 2: wood straight hame collar materials cutting list.**

component	material	# components	total mat [mm]	mat cost [£uk]
hames	50 round timber	2*450	900.00	0.18
padding clips	6mm re bar	2*2*40	160.00	0.02
U loops	6mm re bar	2*3*200	1200.00	0.12
top link	6mm re bar	2*250	500.00	0.05
strap hooks	6mm re bar	2*150	300.00	0.03
top link pins	scrap tyre rubber	1*8*70	10.00	0.10
			<b>TOTAL =</b>	<b>0.49</b>

diameter.

- 3) Make a U-shaped loop from a piece of 8 mm round steel bar for each hame pull loop.
- 4) In each piece of wood drill an 8mm diameter hole 175 mm from one end and another 225 mm from the same end, making sure that both holes are in line with each other.
- 5) Hammer the pull loop into each hame and clench over the ends of the loops to hold them into the hame. The clenched ends must be sunk into the timber so they do not press through the padding into the animal.

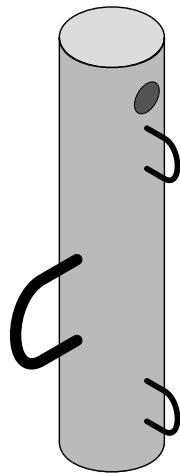

**Figure 7: wood hame with hole drilled for bolt type crossbar.**

TR 27: 15th April 1999

- 6) Hammer a U-nail into the side of each end of each hame in line with the pull loop as shown in the drawings.
- 7) Either:  
cut a slot in the top ends of the hames for the crossbar and make up the crossbar and two rubber pegs to put through the holes in the crossbar.

or:

drill a hole in each hame 40 mm from the top for a crossbar made from a long bolt (Figure 3-11 shows how a long bolt can be made from a short one) and make the long bolt. Figure 7 shows a wooden hame with a drilled hole before padding has been fixed.

or:

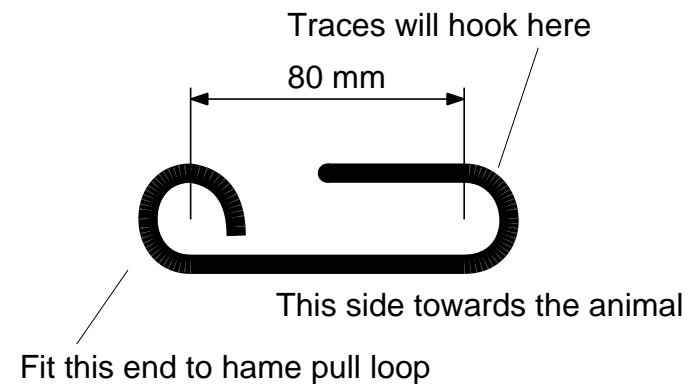

**Figure 8: chain hooks for straps.**

make up leather straps and buckles as in Figure 1. The leather straps can be put through the U-nails to hold them in place.

- 8) Cut a piece padding (carpet, blanket cloth etc) and nail to the hame as shown in the drawings.

### Collar adjustment and method of use

(Remember that protecting the donkey will save money because it can work harder if it is comfortable and will not get sick from skin wounds.)

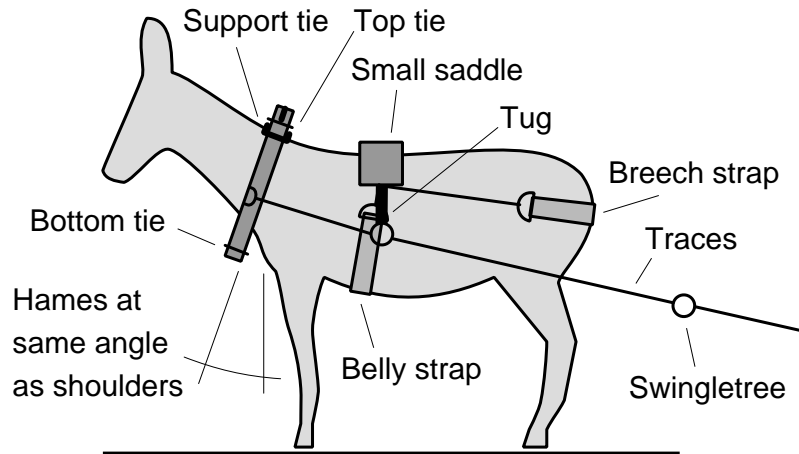

**Figure 9: Collar position on donkey with traces pulling at right angles to hames.**

TR 27: 15th April 1999

- 1) Adjust the top fixing between the two hames so that it is in approximately the right position (once the collar has been used on a particular donkey this will probably not need further adjustment unless the condition of the donkey changes ie it get fatter or thinner).
- 2) Slacken or undo the fixing between the bottoms of the two hames.
- 3) Place the collar over the neck of the donkey and adjust the bottom fixing rope across between the bottoms of the two hames so that it is in approximately the correct position. (If you are using rope for this tie do no tie it properly yet.)
- 4) Now check and adjust both top and bottom fixings between

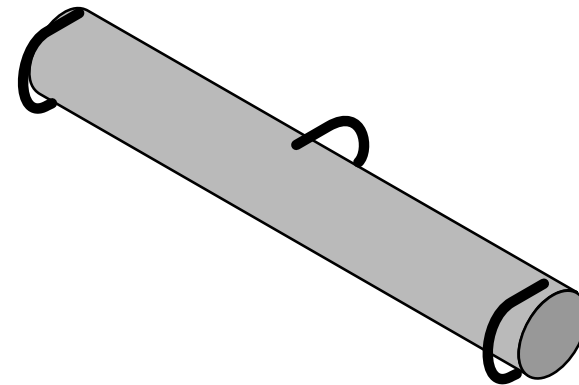

**Figure 10: swingletree: the traces will be tied to the ends, and the implement tied to the central loop.**

the two hames until the collar is in the right vertical position and the angle between the hames fits the donkey's neck. (If you are using rope for the ties, now make the knot properly.)

- 5) Tie the top support rope or strap so that it carries the some of the weight of the collar on the donkey's neck.
- 6) Adjust the lengths of the tugs (the ropes or straps hanging from the saddle if you use one) so that the traces (the ropes or chains which will pull the cart or implement) come back at right angles to the animal's shoulder blades (see Figure 9).

## **Saddles**

With a suitable agricultural implement (plough or weeder etc) It is sometimes possible to pull without using a saddle, but it is usually easier to use a one. This is because ideal angle for the traces is rarely the same as for the implement and using a saddle these can be adjusted independently.

## **Swingletrees**

Whether a saddle is used or not, a swingletree will be needed. A swingletree can be made using the same types of materials as the steel hames. The tube will need to be about 700 mm or 800 mm long depending on how fat the donkey is. You should make sure that the swingletree is long enough so that the

traces do not normally rub on the sides of the donkey when they are tight and the donkey is working. Figure 10 shows a steel swingletree. It is also quite easy to make a wooden one.

If you are going to pull a cart you must use a saddle as shown in Figure 9 because the cart will need some up or down force to stabilise it and a donkey's back needs the protection that a saddle gives.

When pulling a cart fix the breeching strap and the tugs to the shafts. Lead the traces to a swingletree on the front of the cart.

## **Other DTU cart and harness developments**

The DTU has been working on a range of cart designs for use with both donkeys and oxen. It has designs for wooden and steel framed types. You can make either type of cart in only a few hours, if you are reasonably set up with tools and materials.

The DTU has also been working on new designs of wheels, hubs and bearings to bring down their costs and make things more locally manufacturable. It has a system of axles with bearings made from PVC pipe, another with wooden bearings and a third using scrap ball bearings. None of these axles need machining and they only take two men a day to make.

© CE Oram, December 1999

## **Acknowledgements**



Initial trials with these collars were suggested and greatly assisted by Dr Dag Austbo and Mr Martin Aeshlimann from the National Agricultural University of Norway and were hosted by Dr Bruce Joubert in South Africa.

The DTU would also like to thank Dr Pascal Kaumbutho of KENDAT in Kenya and Mr Joseph Mugaga of TOCIDA in Tororo, Uganda for their very considerable help with this project. A large number of other people and organisations have contributed to the success of the project, most notably Mr Anthony Ndungu in Kajjido Kenya, Mr JD Kimani in Kikuyu Kenya and Mr Joseph Gitari in Wanguru Kenya in whose workshops most of the development work of this project was performed. Thanks are due also to Mr Stanley Lameria in Kajaido, Mr Patrick Gitari in Wanguru and Mr Mathew Masai in Machakos for their assistance.

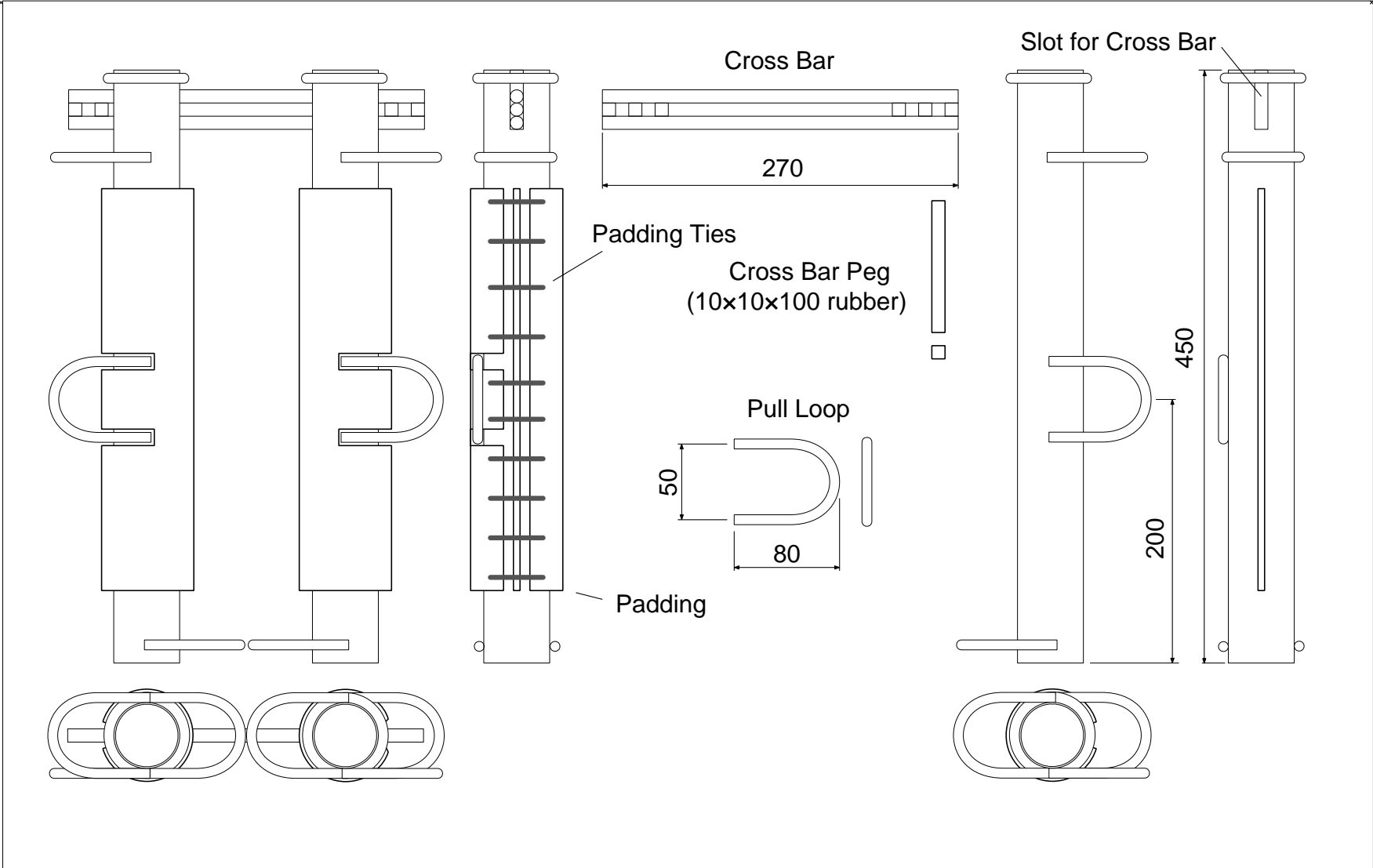

					Scale	25 mm	Title	Straight Hame Donkey Collar of Steel	Drawn by	CEO
					Date	25/12/99			Dwg No	1/1

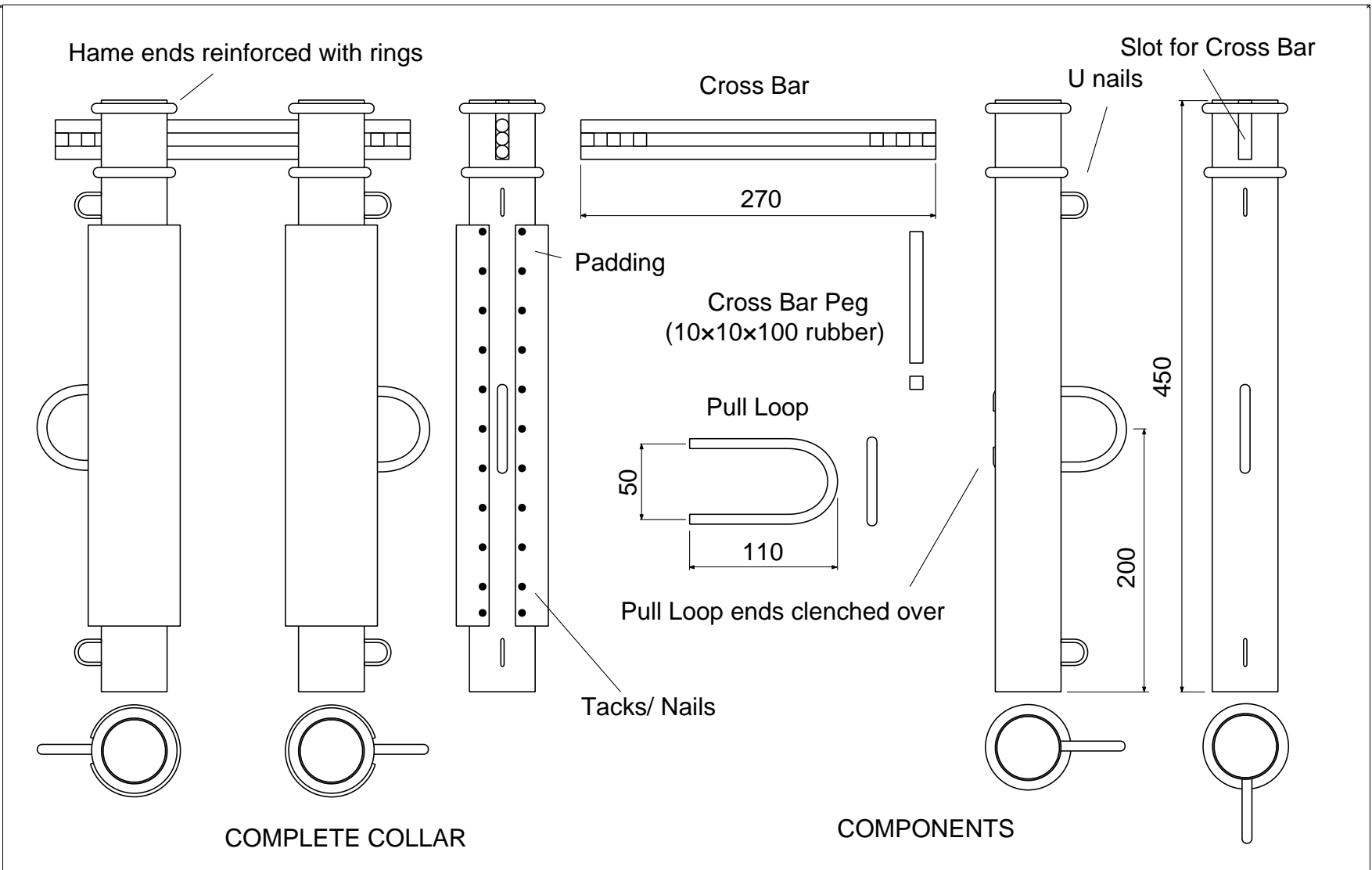

					Scale	25 mm	Title	Straight hame Donkey collar of Wood	Drawn by	CEO
					Date	25/12/99			Dwg No	1/1